

Product Brochure

43"



43 Inch

Portable Advertising Kiosk Display (Android Version)

The information in this document is subject to the current product.

January 2021

I. Product Highlights

- Stylish Design
- Hard-wearing Quality
- Remote Operation
- Remote Publishing
- 7*24 Operation
- High Definition
- Easy To Use
- Customizing Available
- Support Split Screen
- Equipment Status Monitoring



II. Specifications

Category		Portable Advertising Kiosk Display
Series Number		SD-SP430NT
LCD Screen Parameters	Active Area	530.4mm(H)×942.2mm(V)
	Display Resolution	1920(H)×1080(V)
	Display Colors	16.7M
	Brightness	350 cd/m ²
	Contrast Ratio	4000:1
	Angle Of View (Degrees)	89/89/89/89 (Typ.)(CR≥10)
	Service Life	>50000 Hours
	Response Time	6ms (typ.)
Basic Parameters of The Scheme	CPU	RK3368, Eight Cores ARM-A53, 1.8GHz
	GPU	PowerVR G6110
	RAM	DDR 2GB
	ROM	EMMC 8G(16G/32G/64G Optional)
	OS	Android 5.1.1
	Network Support	Standard Configuration: Ethernet, Wireless WiFi, BT Optional: 3G/4G
Input & Output Interface	USB Port	2 PCS
	RJ45	1 PCS
	TF Card Slot	1 PCS
	Speakers	Support Speaker Interface, Up to Two 8 Ω 5W Speaker Output
	HDMI Output	1 PCS
Support Media Format	Video Format	RM/RMVB, MKV, TS, FLV, AVI, VOB, MOV, WMV, MP4, ETC.
	Image Format	BMP, JPEG, PNG, GIF, ETC.
	Audio Format	MP3, WMA

Others	Speaker	Stereo L/R, 8 Ω 5W × 2
	Input Voltage	100~240V 60/50Hz
	Timer Switch	Support
	System Upgrade	Support TF Card Upgrade
Environmental Factor		Operating Temperature: -10°C ~ 50°C
		Storage Temperature: -20°C ~ 60°C
Accessory Package		Manual, Warranty Card, Certificate, Power Cord, Wifi Antenna (configured According To Different Versions)
Structure Size	Appearance Material	Safety Rounded Corner Design, Aluminum Alloy Frame, High-quality Sheet Metal, 5 Years Of Protection
	Dimensions (length * Width * Thickness)	1750*592.8*21mm
	Gross Weight (Packaging)	32kg (for Reference Only, Actual Product Shall Prevail)

III. Product Dimension

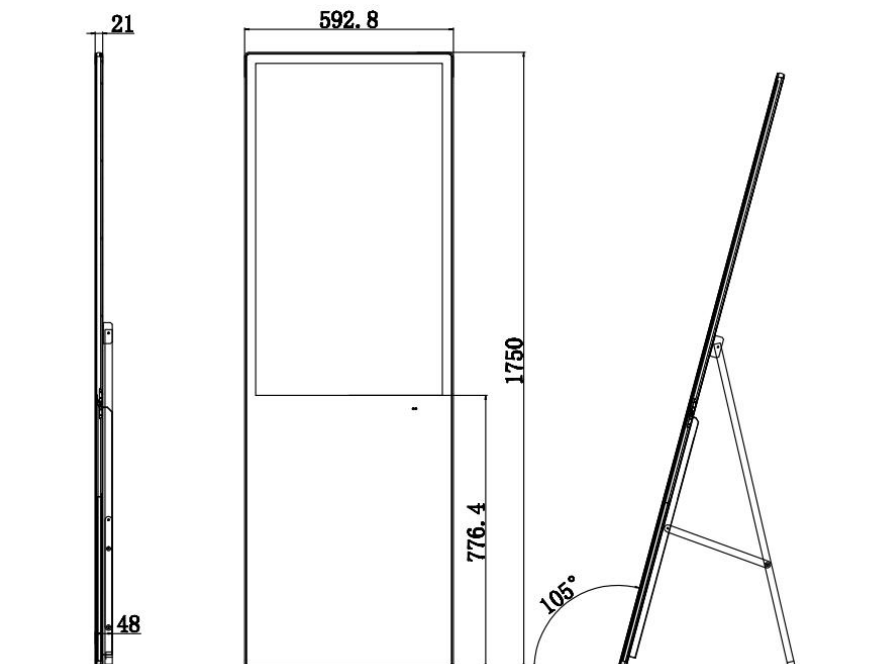

製品のお見積り・お問い合わせ

株式会社プラズモニックジャパン

✉ info@plazmonic.jp ☎ 045(663)1402

IV. Product Advantages

- **Accurate Target Audience**

Target audiences who are about to buy

- **New Form of Publicity**

The form of multimedia next to the goods is currently the most fashionable and novel form of advertising in shopping malls

- **Effective Cooperation With TV Advertisement**

1% Of TV Advertising Costs, 100% To Deepen The Effect Of TV Advertising. It Can Be Consistent With The Content Of TV Commercials, Reminding Consumers To Buy at the Sales Terminals

- **High Value-added Product**

Advertising & Information Release

- **Long Advertising Period**

It Works 365 Days/Year for Promotion. No Manual Is Required. The Cost Is Extremely Low. The Audience Is Extremely Broad.

V. Applicable Scenarios

- **Public Places**

Subway, Airport, Park, Exhibition Hall, Stadium, Museum, Conference, Lottery Center

- **Educational Institution**

Various Schools, Off-campus Educational Institutions, Administrative Agencies

- **Financial Institution**

Banks, Securities, Funds, Insurance Companies, Exchanges, Pawn Shops

- **Commercial Organization**

Shopping Malls, Franchises, Hypermarkets, Hotels, Travel Agencies, Restaurants

- **Entertainment Venues**

Cinemas, Fitness Centers, Resorts, Entertainment Venues, Bars, Beauty Salons

- **Real Estate**

Apartments, Villas, Office Buildings, Commercial Buildings, Sales Offices

VI. Case Show

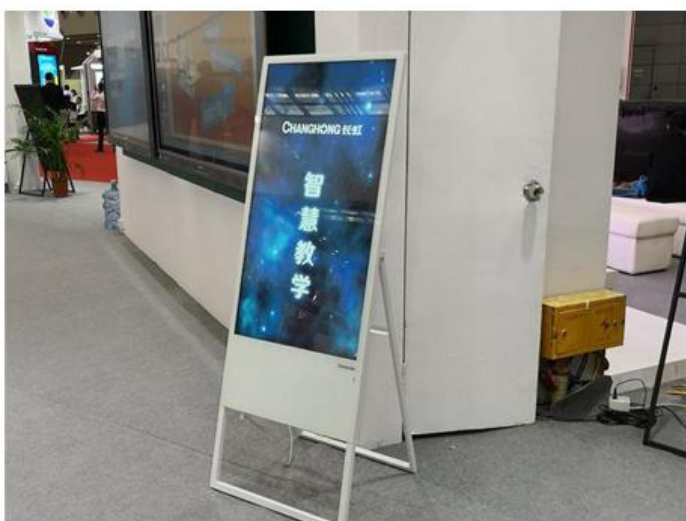

製品のお見積り・お問い合わせ

株式会社プラズモニクジャパン

✉ info@plazmonic.jp ☎ 045(663)1402

VII. After-sales Policy

- **Warranty Period**

The warranty period is one year from the date the product arrives at the destination port. During the warranty period, if the small parts are defective, they can be replaced by express delivery. If the complete unit has to be returned for maintenance, the freight is to be covered by the sending side.

- **Extended Warranty**

The warranty period can be extended to 3 years. The price of the whole machine is increased by 15%. During the warranty period, both parties shall bear his one-way freight.